



PUMPS AT A GLANCE





RAPID ALLWEILER PUMPS HEAD OFFICE

WE HAVE ALL THE TICKS

- DEEP APPLICATION KNOWLEDGE
- TAILOR MADE PUMPING SOLUTIONS
- STATE OF THE ART TRAINING CENTRE
- LEADING PROVIDER OF TOP QUALITY PRODUCTS
- LOCAL MANUFACTURE
- FOUNDED IN 1932
- OWN FOUNDRY
- ACCREDITED PUMP REPAIR/SERVICE WORKSHOP
- ISO 9001:2008
- BEE ACCREDITED
- AFTER MARKET SERVICE



FOUNDER A J HINDRY



OWN WORKSHOP

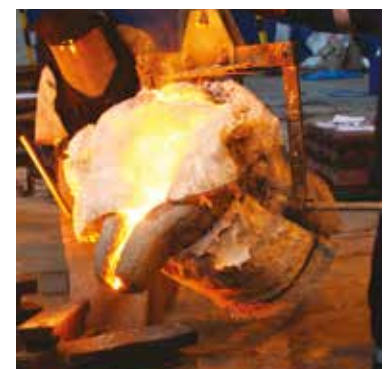

OWN FOUNDRY

Version 2 - Pumps at a Glance: Rapid Allweiler Pumps

Whilst all care has been taken to ensure the accuracy of the information contained in this brochure was correct at the time of printing, please be advised we cannot be held responsible for any errors contained within and or changes that may have taken place. For confirmation of any information contained here within please contact a member of our technical sales team.

COLFAX
Fluid Handling

ALLWEILER[®]

OUR FOUNDRY

CRITICAL SUPPLIER DEVELOPMENT - QUANTUM FOUNDRY GROUP

CUTTING DOWN ON LEAD TIME

Since April 2013 Rapid Allweiler has been working exclusively with the Quantum Foundry Group to develop high quality, competitive and timeous supply for all our casting needs. Initially starting with the production of Stainless steel castings, we have further developed the Quantum Foundry Group to supply all of our casting requirements. The production of cast Iron and Ductile iron was introduced in 2014 with impeller castings coming on line in mid 2015. The implication of this CSDP initiative has given us the opportunity to set the bench mark for lead times and has added enormous advantages in flexibility and delivery for our clients. Developing this supply chain also enables us to be more responsive to our clients requirements, from specialized casting in exotic material, to castings adaptions / modifications from standard patterns.

An essential part of the foundry development was to ensure that the Quantum Foundry Group can meet our needs. Material identification is an integral part and the Quantum Foundry Group utilizes and SpectroMaxx spectrometer specifically for this purpose.

QFG

Quantum Foundry Group operates two furnaces of 350kg each, with an annualized capacity of approximately 2000 tones. Moulds are made using a resin bonded sand on a continuous loop system, The sand is reclaimed and reused. Quality control is handled throughout the process and is the lead responsibility of our in house Metallurgist. Materials currently being cast included Stainless Steel, Cast Iron, Ductile Iron and Bronze with special alloys available on request. Being a " Small " Foundry lets us be very responsive to the client demands and special request.



OUR FACTORY

RAPID FACTORY - YOUR SINGLE SOURCE

THE RIGHT PUMP FOR THE RIGHT APPLICATION

Rapid Allweiler’s product range is specifically engineered to meet market demands with over 220 years of combined national and international pump and engineering experience. A team of experts can provide pumping solutions for just about any industry requirement - whether it is chocolate or water that needs to be moved.

Today, Rapid Allweiler boasts some 400m2 of office, manufacturing and conferencing space, servicing branches in Cape Town and Durban as well as a nation-wide dealer network.

Rapid Allweiler’s mission is to continue to offer clients innovative solutions, combined with the highest quality products and unrivalled service.



OUR PRODUCTION PROCESS

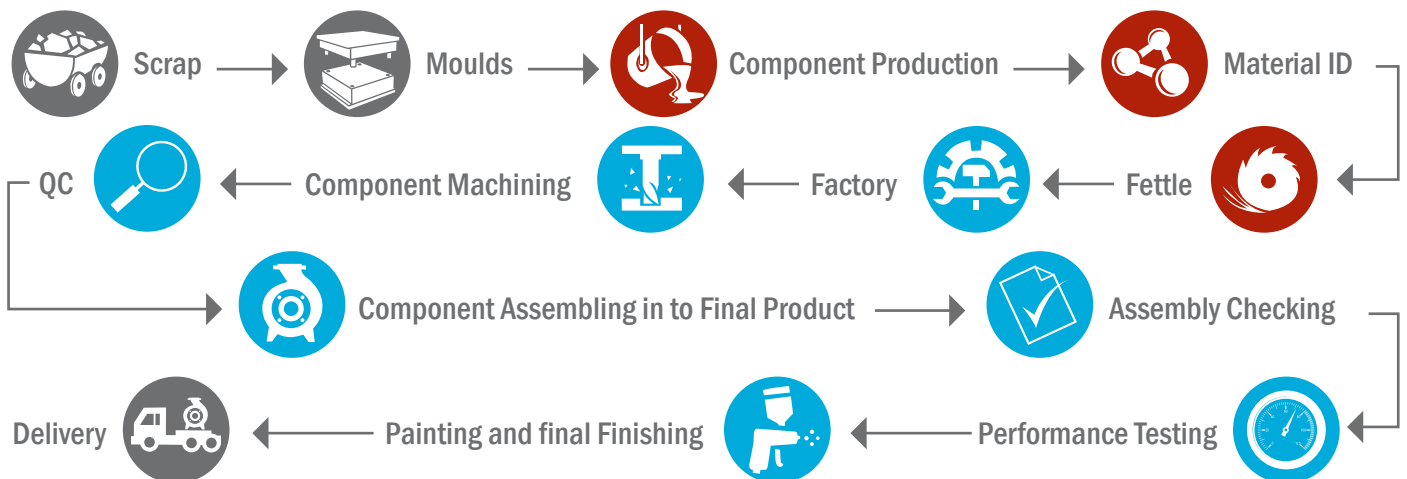

PUMP REPAIR

PUMP REPAIR / MAINTENANCE CONTRACTS

PUMP REPAIR

- Our pump repair facilities offers you Peace of Mind knowing that your pump will be repaired to its original standard with only genuine parts. All repairs are carried out in our controlled repair work shop by qualified pump fitters.
- Pumps repaired by us will give you the confidence that your pump will last for many years, trouble free.
- Can't get the pump to us? No problems – we'll come to you. Pump repairs are available on site from one of our mobile pump repair teams.

MAINTENANCE CONTRACTS

- We would love to chat with you about our maintenance contract. We will take all your heads aches away by servicing your pumps as required depending on operating conditions.
- We can do on site service weekly/monthly/yearly and will tailor make our offer to include all aspects of the pumps which are critical to you.

For Example:

Simple contract (non critical applications) - Monthly on site service to check the following:

- Visible inspection
- Thermal inspection
- Vibration analysis
- Pump alignment

Extended contract (critical applications) - Monthly on site service plus preventative maintenance work:

- All aspect of simple contract
- Plus internal pump inspection
- Critical spares replacement at agreed intervals with
- guaranteed availability
- Laser alignment

We can also offer ON SITE ALIGNMENT.





TEST YOUR PUMP

PUMP PERFORMANCE TEST

- We have a state of art testing facility.
- We can do a wide variety of testing options from simple flow + head to full ISO 9906 acceptance test.
- Full witness testing is available if you wish to come along.



CONTENTS



16



17



18



19



20

APPLICATION/ INDUSTRY	NT/NSHD	NB	NTT/NIT	DV	L SERIES
Acids	•	•		•	
Air Conditioning	•	•			•
Agricultural	•	•			•
Boiler Feeds	•	•			•
Booster Pumps	•	•		•	•
Chemical & Petrochemical	•	•		•	
Chemical & Pharmaceutical	•	•		•	•
Chemical Process			•		
Cooling Circuits	•	•			•
Demineralised Water	•	•		•	
Dewatering				•	
Fire Fighting	•	•		•	•
Food & Beverage	•	•			
Heating & Cooling System	•	•	•	•	•
Irrigation	•	•			•
Lubrication					
Mineral Oil	•	•	•		
Mining	•	•	•	•	•
Paper & Pulp	•	•	•		•
Paint, Lacquer & Inks			•		
Petro Chemical	•	•		•	
Pipelines & Tank Farms	•	•	•		•
Power Generation	•	•	•	•	•
Sewage	•	•		•	
Sludge					
Sugar Industry	•	•		•	•
Swimming Pools	•	•			
Textile	•	•	•		•
Thermal Oil Transfer			•		
Wastewater	•	•		•	
Water	•	•		•	•
Wood			•		



**APPLICATION/
INDUSTRY**

ANSI ²¹

CLT ²²

CLB ²³

SP ²⁴⁻²⁵

HSC ²⁶

Acids

Air Conditioning

Agricultural

Boiler Feeds

Booster Pumps

Chemical &
Petrochemical

Chemical &
Pharmaceutical

Chemical Process

Cooling Circuits

Demineralised
Water

Dewatering

Fire Fighting

Food &
Beverage

Heating & Cooling
System

Irrigation

Lubrication

Mineral Oil

Mining

Paper & Pulp

Paint, Lacquer
& Inks

Petrochemical

Pipelines &
Tank Farms

Power Generation

Sewage

Sludge

Sugar Industry

Swimming Pools

Textile

Thermal Oil Transfer

Wastewater

Water

Wood

•

•

•

•

•

•

•

•

•

•

•

•

•

•

•

•

•

•

•

•

•

•

•

•

•

•

•

•

•

•

•

•

•

•

•

•

•

•

•

•

•

•

•

•

•

•

•

•

•

•

•

•

•

•

•

•

•

•

•

•

•

•

•

•



27

OT



28

SKID BASE



29

FIRE SYSTEM



30

RENTAL UNIT



31-302

SCREW PUMPS

APPLICATION/
INDUSTRY

OT	SKID BASE	FIRE SYSTEM	RENTAL UNIT	SCREW PUMPS	APPLICATION/ INDUSTRY
	•		•	•	Acids
	•		•		Air Conditioning
•					Agricultural
	•				Boiler Feeds
	•		•		Booster Pumps
•	•		•	•	Chemical & Petrochemical
•	•		•		Chemical & Pharmaceutical
•	•		•	•	Chemical Process
					Cooling Circuits
•	•		•		Demineralised Water
•			•		Dewatering
	•	•	•		Fire Fighting
•	•		•	•	Food & Beverage
•	•		•		Heating & Cooling System
•	•		•		Irrigation
				•	Lubrication
	•		•	•	Mineral Oil
•		•	•	•	Mining
•	•	•	•	•	Paper & Pulp
•	•		•	•	Paint, Lacquer & Inks
•	•		•	•	Petrochemical
•			•	•	Pipelines & Tank Farms
•	•	•	•	•	Power Generation
•	•		•		Sewage
•	•		•		Sludge
•		•			Sugar Industry
	•		•		Swimming Pools
•	•		•	•	Textile
	•		•	•	Thermal Oil Transfer
•			•		Wastewater
•	•		•		Water
					Wood



33-35

IMO PUMPS

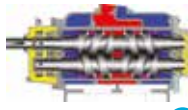

36

TWO SCREW PUMPS



37-39

PC



40

MACERATORS



41

PERISTALTIC PUMPS

**APPLICATION/
INDUSTRY**

Acids	•	•	•		
Air Conditioning					
Agricultural		•	•		
Boiler Feeds					
Booster Pumps		•			
Chemical & Petrochemical	•		•		•
Chemical & Pharmaceutical	•	•	•		•
Chemical Process	•		•		•
Cooling Circuits					
Demineralised Water	•			•	
Dewatering		•			
Fire Fighting					
Food & Beverage		•	•		•
Heating & Cooling System					
Irrigation					
Lubrication					
Mineral Oil	•	•	•		
Mining				•	•
Paper & Pulp		•	•		•
Paint, Lacquer & Inks	•		•		•
Petrochemical	•	•	•		
Pipelines & Tank Farms		•			
Power Generation	•	•	•		•
Sewage			•	•	•
Sludge		•	•	•	•
Sugar Industry		•	•		•
Swimming Pools		•			
Textile			•		•
Thermal Oil Transfer	•	•	•		
Wastewater				•	•
Water		•	•		•
Wood					

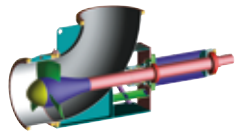

PROPELLER PUMPS

42



IN-1000®

43-44



ALL-FUEL®

45



LSC

46



AFFILIATES

APPLICATION/
INDUSTRY

Acids

Air Conditioning

Agricultural

Boiler Feeds

Booster Pumps

Chemical &
Petrochemical

Chemical &
Pharmaceutical

Chemical Process

Cooling Circuits

Demineralised
Water

Dewatering

Fire Fighting

Food &
Beverage

Heating & Cooling
System

Irrigation

Lubrication

Mineral Oil

Mining

Paper & Pulp

Paint, Lacquer
& Inks

Petrochemical

Pipelines &
Tank Farms

Power Generation

Sewage

Sludge

Sugar Industry

Swimming Pools

Textile

Thermal Oil Transfer

Wastewater

Water

Wood

INDUSTRIES

INDUSTRIAL - YOUR SINGLE SOURCE

REDEFINING WHAT MATTERS MOST TO YOU

Pumps and fluid handling systems from Rapid Allweiler Pumps are offered under the trusted brands Allweiler®, Houttuin™, Imo® and Warren®. These solutions support a wide range of mission critical applications and are essential for the reliable and safe operation of all types of industrial systems, including sewage plants; process technology and chemistry; mining; pulp and paper; building and construction; production of food, beverages, and cosmetics; polymers/textiles processing; heat transfer; and machine tool.

Through our standard and custom engineered solutions, we offer a wide range of designs for fluid handling systems in industrial systems.

Industrial plant operators and engineers turn to Rapid Allweiler Pumps to help redefine the metrics that matter most to them:

- **Technology:** providing the right pumping and system solution for every application
- **Reliability:** maintaining performance of the system regardless of operating conditions
- **Availability:** maximizing the time for production
- **Uptime:** ensuring run-time consistency without fail
- **Compliance:** sustaining the commitment to environmental responsibility
- **Cost-effectiveness:** keeping the plant competitive in a tough global economy



APPLICATIONS

CP CHEMISTRY & PROCESS TECHNOLOGY

- Pumping of acids and lyes, washing and absorption liquids, salt solutions, solvents, hot liquids

HT HEAT TRANSFER

- Pumping of thermal oil
- Pumping of hot water
- Pumping Rivers and Dams for Irrigation

BC BUILDING & CONSTRUCTION

- Pumping of fuel oil
- Supply of warm and cold water, heating systems
- Elevator technology, lifting platforms, theatrical stages

MI MINING

- Pumping and dosing of chemicals and explosive liquids
- Pumps used in: Mining & Drilling
- Lubrication and control of oremining machines



MT MACHINE TOOL

- Pumping of cooling-lubricant solutions and emulsions, cutting and grinding oils
- High-pressure coolant feed for internally cooled tools
- Pumps for cooling-lubricant supply systems (individual and centrally managed)

PP PULP & PAPER

- Pumping of coating inks (pigments, binders, additives), kaolin, calcium carbonate, latex, starch, caustic soda, paper stock
- Dosing of additives and chemicals
- Supply pumps for lamination, coatings, and cooking

WW WATER & WASTEWATER

- Pumping of various sludges: raw, pre-clarification, waste, activated, digested, post-clarification, re-circulated and thickened
- Dosing of neutralizing agents and flocculants
- Complete solutions for pre- and post-clarification, recirculation, de-nitrification and nitrification
- Industrial wastewater treatment in clarification plants

FC FOOD & COSMETICS

- Pumping of fibrous liquids, liquids with solids, high value and sensitive liquids
- Dosing in batch operation, in filling systems, for additives, or during product blends

A AGRICULTURAL

- Pumping for irrigation from rivers and dams

PT POLYMERS & TEXTILES

- Pumping of starting products for fiber production
- Process pumps in polyester manufacturing

POWER GENERATION - YOUR SINGLE SOURCE

REDEFINING WHAT MATTERS MOST TO YOU

Pumps and fluid handling systems from Rapid Allweiler Pumps product brands Allweiler®, Houttuin™, Imo® and Warren® support a wide range of mission critical applications in all types of power plants: Combined Cycle, Combustion, Steam, Stationary Diesel, Solar Power, Cogeneration and Hydro.

Through our standard and custom engineered solutions, we offer a wide range of designs for fluid handling systems in power generation applications.

Power generation operators and engineers turn to Rapid Allweiler Pumps to help redefine the metrics that matter most to them:

- **Technology:** providing the right pumping and system solution for every application
- **Reliability:** maintaining performance of the system regardless of operating conditions
- **Availability:** maximizing the time for production
- **Uptime:** ensuring run-time consistency without fail
- **Compliance:** sustaining the commitment to environmental responsibility
- **Cost-effectiveness:** keeping the plant competitive in a tough global economy



APPLICATIONS

- H HYDRO**
 - Lubrication
 - Hydraulic governor
 - Bearing lift
 - Oil service
- SL SOLAR**
 - Heat transfer fluids
- CB COMBUSTION**
 - Fuel unloading
 - Fuel Forwarding
 - Fuel transfer
 - Rotor jacking
 - Lubrication
 - Fuel injection
 - Chemical metering
 - Seal oil

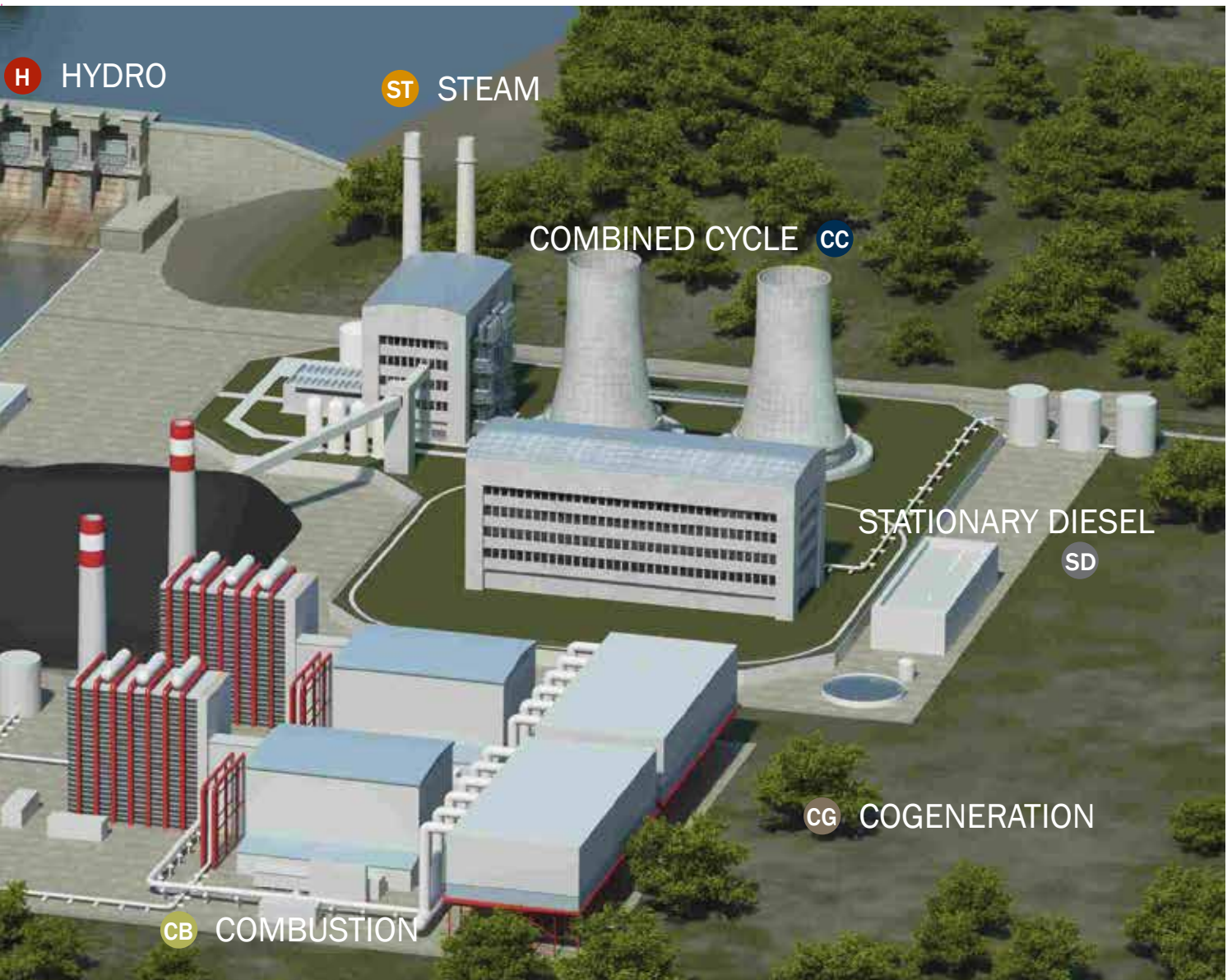

ST STEAM

- Fuel transfer
- Fuel unloading
- Rotor jacking
- Lubrication
- Fuel or burner injection
- Waste water treatment
- Oil service
- Seal oil
- Chemical metering

CC COMBINED CYCLE

- Fuel transfer
- Rotor jacking
- Lubrication
- Oil service
- Seal oil
- Purge water
- Washing system
- Cooling water
- Nox reduction
- Sump
- Fuel or burner injection
- Waste water treatment

SD STATIONARY DIESEL

- Fuel unloading
- Fuel forwarding
- Fuel transfer
- Fuel injection
- Lubrication
- Cooling water

CG COGENERATION

- Lubrication
- Rotor jacking
- Oil service
- Fuel transfer
- Fuel or burner injection

OIL & GAS

WHEN AND WHERE YOU NEED THEM

Whether in the jungles of Colombia, the deserts of the Sahara or the icy waters of the polar circle, you can depend on Rapid Allweiler Pumps to meet your oil and gas needs.

Our Global presence and industry-leading product application experience ensure you get the right answer whether you produce, transport, store or refine. And because you're working with a unique company that knows where the fluid comes from and where it needs to go, you can always count on maximum efficiency, reliability, output and uptime.

Rapid Allweiler Pumps has worked with customers around the world to match or meet product performance requirements to published standards. Examples include API 676,, API 614, API 682 and NACE. Our product portfolio focuses on positive displacements pump technology and extends to multiphase, lubrication and gas compression systems.

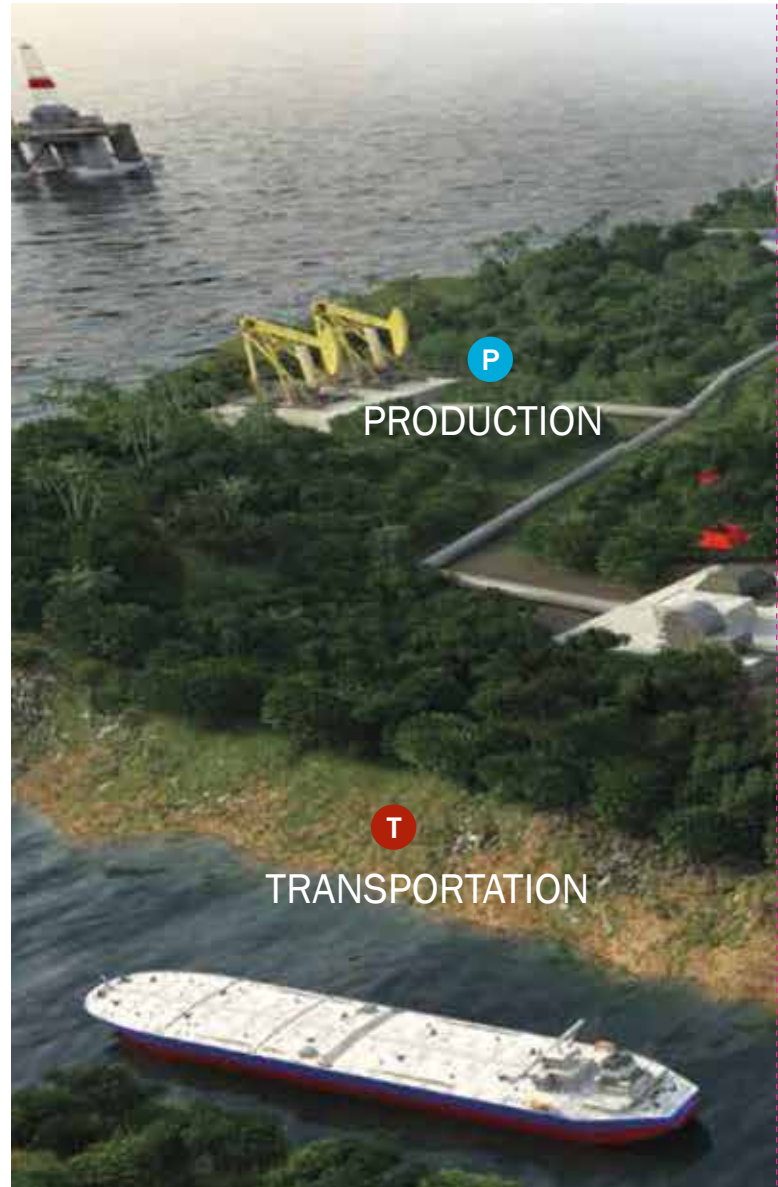

P Production **T** Transportation **S** Storage **R** Refining

Three-Screw Pumps **P** **T** **S** **R**

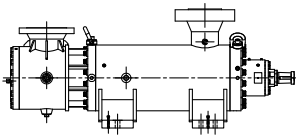

Flow rates up to 2,500gpm (568m³/h)
 Pressure up to 2,000psi (142bar)
 Maximum Temperature up to 107°C

External Gear **T**

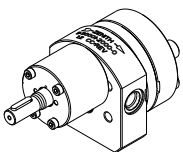

Flow rates up to 9gpm (2m³/h)
 Pressure up to 2,500psi (170bar)
 Max fluid Temperature up to 510°C

Progressing Cavity **P** **T** **S** **R**



Flow rates up to 1,980gpm (450m³/h)
 Pressure up to 580psi (40bar)
 Maximum Temperature up to 150°C

Two-Screw Pumps **P** **T** **S** **R**

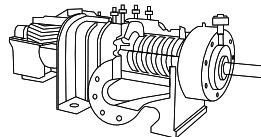

Flow rates up to 24,500gpm (5,550m³/h)
 Differential pressure up to 1,400psi(100bar)
 Maximum Temperature up to 398°C

Lubrication Systems **R**

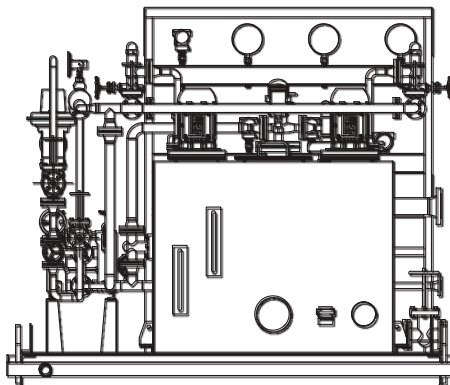

API 614 Chapter 2
 Special Purpose
 API 614 Chapter 3
 General Purpose



R REFINING

S STORAGE

Compressor Packages

P

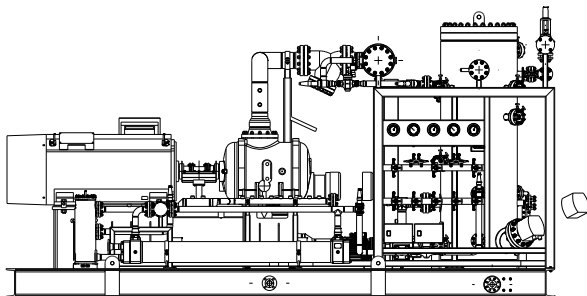

Howden Compressors Ltd. approved OEM packager for over 50 years
 PressurPackages cover a range from 300–14,000 m³/he up to 2,000psi (142bar)
 Installed motor power up to 3.5 MW
 API 619
 API Plan 52, 53 and 72 seal systems

Multiphase Systems

P

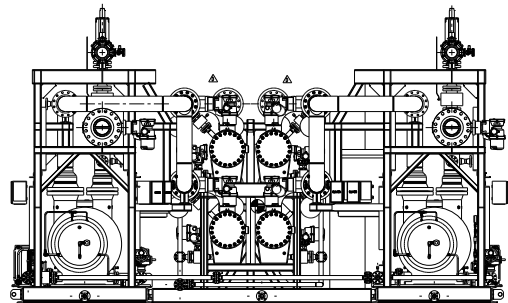

Self-priming, double entry, horizontal pump types
 Pump flow rates from 132–6,737 gpm (30–1,530 m³/h)
 Differential pressure ratio 14–350 psi (1–25 bar)
 Casing pressure 728–1,400 psi (52–100 bar)



NT, NSHD & NB MONOBLOCK

END SUCTION CENTRIFUGAL PUMPS TO EN733 (DIN 24255)

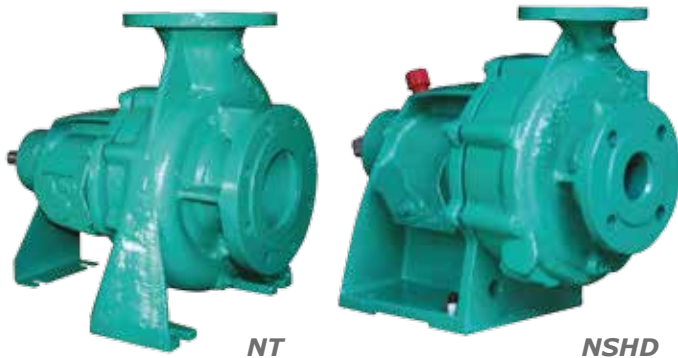

APPLICATION

- Air Conditioning
- Water Supply
- Irrigation
- Water Treatment
- Circulating and Heating Systems
- Swimming Pools
- Chemical and Petrochemical Industries

RA PUMP RANGE	MINIMUM FLOW (m ³ /h)	MAXIMUM FLOW (m ³ /h)	MINIMUM HEAD (m)	MAXIMUM HEAD (m)	MAXIMUM TEMPERATURE
NT & NSHD	2	1100	3	140	160°C
NB	2	530	3	140	160°C

DESCRIPTION

- Suitable for **clean liquids** which are not chemically aggressive to the pump materials.
- Standard as **single stage** pumps with a variety of sizes offering a **two stage** options.
- Interchangeability - The entire range offers 40 different sizes, utilizing only 5 bearing brackets, therefore allowing for less stock holding.
- Pump Flanges are rated for 10 bar and drilled to EN 1092.1 (PN 10/DIN 2532).

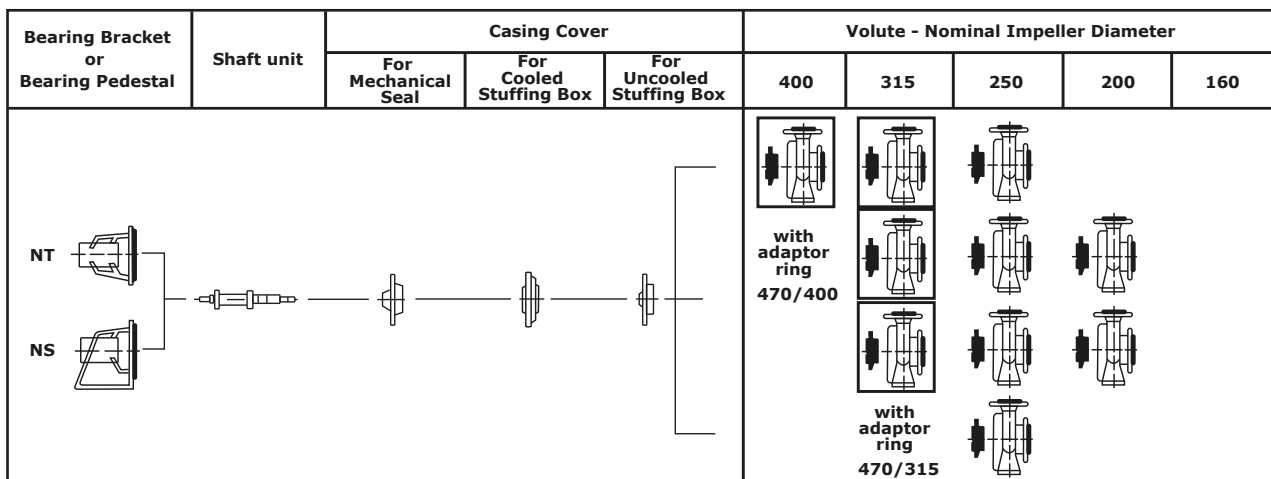



NB



NT Pump Station

Two Stage Centrifugal Pumps

- Two stage pumps are able to achieve much higher pressures and require substantially lower NPSH.
- The versatility of this design allows for conversion from single stage to two stage, or vice versa without the need for machining of the parts.

NT

- **Sealed for life** deep grooved ball bearings, offer a maintenance free life cycle. (40 000 hours).
- **Back pull out** design for ease of maintenance, allowing the pump to be disassembled (for routine maintenance) without removing the volute casing from the pipe work provided a spacer type coupling is fitted.

NSHD

- **The volute may be rotated** to facilitate alternative discharge pipe work installations.
- Heavy duty oil lubed **angular contact bearings** are fitted which makes the pump ideal for belt drive applications.

NB

- Utilises the volutes and impellers from our well established NT and NSHD range of pumps.
- **Stub shaft** design which is attached onto the motor shaft, therefore the pump runs off the motor bearings and does not utilize it's own bearing assembly.
- The volute casing is attached to the motor by means of a pump to motor bracket, thus **space saving** option when compared to long coupled pumps. The **closed coupled design** is also more economical, **cost saving design** because it does not require a base plate.

Motor

Standard I.E.C flange mounted or foot and flange mounted, three phase 380 or 525 volt, totally enclosed fan cooled motors are used with either cast iron or aluminium frames.



NTT & NIT

CENTRIFUGAL PUMPS TO EN733 (DIN 24255)



NTT



NIT (In-line option)

APPLICATION

- Chemical and Pharmaceutical Industry
- Mineral Oil
- Food, Laundries and Textile
- Leather and Paper
- Wood Manufacturing
- Paint and Lacquer
- Building, Tar and Bitumen
- Electrical Engineering Industries

RA PUMP RANGE	MINIMUM FLOW (m ³ /h)	MAXIMUM FLOW (m ³ /h)	MINIMUM HEAD (m)	MAXIMUM HEAD (m)	MAXIMUM TEMPERATURE
NTT / NIT	3	530	3	130	350 °C

DESCRIPTION

- **Thermal oil** pumps capable of handling temperatures up to **350 °C** in heat transfer plants without the necessity for external cooling of the pump.
- The fluids pumped must have **lubricating** properties and should not contain any solids or abrasive particles, as the non drive end bearing and mechanical seal is lubricated by the pumped liquid.
- The **unique heat dissipation design** of the bearing housing ensures a reduced temperature at the mechanical seal faces and the bearings.

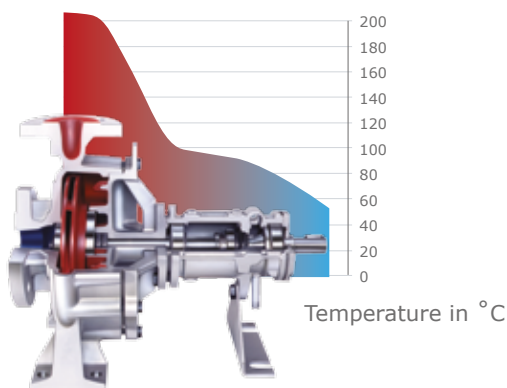

- **Back pull out** for ease of maintenance.
- These pumps are further equipped with a **safety stuffing box** and throttling area in front of the mechanical seal. In case of a seal failure this prevents the pumped liquid from emerging in a hazardous quantity or manner. With drain connection adequate piped up, the safety requirements of DIN 4754 are exceeded. (The pumps have a drain connection to ensure that any seepage past the shaft sealing can be safely drained through this connection).
- High temperature bearings are fitted where applicable).
- Pump flanges according to PN 16 EN 1092-1.
- No special motor or coupling guard required due to unique heat dissipation design.



DV

VERTICAL SPINDLE CENTRIFUGAL PUMPS TO EN733 (DIN 24255)



APPLICATION

- Industrial
- Agricultural
- Refinery
- Mining Industries
- Lubrication System

RA PUMP RANGE	MINIMUM FLOW (m ³ /h)	MAXIMUM FLOW (m ³ /h)	MINIMUM HEAD (m)	MAXIMUM HEAD (m)	MAXIMUM TEMPERATURE
DV	4	400	3	90	120°C

DESCRIPTION

- Vertical spindle design with the motor mounted at the top and the hydraulic end **submerged in the pumped media**.
- Specialised mechanical seal arrangement allows the pump to handle liquids with **solids in suspension** and they can also **run dry for short periods**.
- Suitable for wet and dry pit installation.
- Two bearing bracket frame sizes for the entire range offer **high interchangeability** of spare parts.
- **Solid stainless steel shaft** supported by two heavy duty ball bearings in the column. The pump column is sealed by means of a double mechanical seal arrangement in an oil chamber.
- Maximum column length of **2400 mm (2.4meters)**
- **Replaceable shaft sleeves** are fitted to the shaft at all wearing points and all parts are easily removed for inspection or service.



Complete 316 Stainless Steel Pump for Brazil



L

HIGH PRESSURE MULTISTAGE CENTRIFUGAL PUMPS



APPLICATION

- Water Supply and Irrigation
- Boiler Feed
- Booster Pumps
- Cooling and Heating Systems
- Fire Fighting
- General Industrial Applications

RA PUMP RANGE	MINIMUM FLOW (m ³ /h)	MAXIMUM FLOW (m ³ /h)	MINIMUM HEAD (m)	MAXIMUM HEAD (m)	MAXIMUM TEMPERATURE	SUCTION PRESSURE	INTERNAL PRESSURE	SPEED
L	3	1000	6	1000	160°C	Up to 10 bar	Up to 25 bar	Up to 3500 rpm

DESCRIPTION

- This pump design simulates pumping in series at a fraction of the cost, utilizing closed impellers separated by interstage casings and diffusers.
- The shaft is sealed by packed gland or mechanical seal arrangement.
- Replaceable shaft sleeves are fitted as standard.
- Suction flanges PN16/DIN 2533, delivery flanges PN40/DIN 2535.
- Pumps are driven from the suction end and the direction of rotation is clockwise (viewed from the drive end).
- Grease lubricated grooved ball bearings are arranged on each side of the bearing housing brackets to absorb any residual forces.

[L25 - L65](#)

- The shaft is supported by a bearing on either end which eliminates any over hanging forces while axial thrust is compensated by **balance holes** in each impeller.

[L80 Upwards](#)

- Bearings are kept in position at all times by means of a **balance discs**.



ANSI

HEAVY DUTY PROCESS PUMPS



Open Impeller

APPLICATION

- Chemical
- Petrochemical
- Pulp & Paper
- Primary metals
- Pharmaceutical
- Textile
- Food

RA PUMP RANGE	MINIMUM FLOW (m ³ /h)	MAXIMUM FLOW (m ³ /h)	MINIMUM HEAD (m)	MAXIMUM HEAD (m)	MAXIMUM TEMPERATURE
ANSI	2	900	3	140	260°C

DESCRIPTION

- Single stage end suction centrifugal pump with **semi open impeller** allowing it to handle **solids up to 25mm**.
- **Back pull out** feature allows for the removal of the entire rotating assembly without disturbing the suction and discharge pipe work provided a spacer coupling is fitted.
- The volute casing has **horizontal suction** and **vertical discharge flanges**.
- 150lb flanges as standard and for heavy duty applications 300lb flanges are optional (ANSI B16.5).
- The **impeller is semi open** with partial shrouds for maximum vane support without the high thrust that is inherent in full shroud designs. It is matched to casing for high efficiency and enables excellent passage for solids.
- **Wear adjustment** within the bearing assembly design allows for hydraulic performance to be maintained by an external impeller adjustment, thus giving extended maintenance intervals on the pump.

This pump offers a wide variety of features:

- Stuffing box can be jacketed for heating or cooling.
- Factory machined for wide range of sealing options including internal and external mechanical seals and has tapped openings for external flushing if required.
- The bearing frame is constructed of Heavy-duty cast-iron with large oil reservoir and water jacket. The Oil level is monitored by sight glass. Oil seals on each end and oil breather fully protects oil from contamination while allowing for expansion and contraction of air caused by ambient temperature change (bearing isolators – optional).
- The shaft is fitted with a renewable shaft sleeve with one end free to expand to handle temperature variations.
- The **wet end** parts are standard in **heavy duty cast stainless steel**, though can be supplied in a wide variety of materials per the applications, e.g. CD4MCu, Alloy-20, Monel, Nickel, Hast-C, Hast-B, and WCB.



CLT & CLB

END SUCTION CHEMICAL PROCESS PUMPS TO EN 22858 (DIN 24256)



CLT



CLB

APPLICATION

- Pharmaceutical
- Food and Beverage
- Air Conditioning
- Paints and Inks
- Steel Manufacturing
- Chemical Industry

RA PUMP RANGE	MINIMUM FLOW (m ³ /h)	MAXIMUM FLOW (m ³ /h)	MINIMUM HEAD (m)	MAXIMUM HEAD (m)	MAXIMUM TEMPERATURE
CLT	2	1050	3	140	180°C
CLB	2	450	3	140	180°C

DESCRIPTION

- These pumps are single stage, end-suction and of modular design with a **high interchangeability of parts**.
- They are suitable for pumping clean liquids and **highly aggressive chemicals**.
- Excellent hydraulic performance with **low N.P.S.H required values**.
- The suction flange is horizontal and the discharge is vertical.
- Standard flanges conform to DIN 2543 PN16.
- The wet end components of the pump (Volute, Impeller and Seal or Gland Plate) are supplied standard in **high grade Cast Stainless Steel** for long life.

- They have overhung impellers, hydraulic balance is effected by balance holes in the impeller. Standard construction is with soft packed stuffing box or single, unbalanced mechanical seal.
- The entire range offers a high interchangeability, thus reducing spares stock holding.

CLT

- **Back pull out** feature for ease of maintenance, allowing the volute casing to remain connected to the pipework when removing the rotating assembly.
- Shaft is supported by **sealed for life** deep groove ball bearings, allowing for a maintenance free life cycle.
- Bearing assemblies from our EN 733, NT-Range are utilized allowing a high **interchangeability** of spares.



CLB

- Single end-suction centrifugal pump with volute and impeller from our well established CLT range of pumps.
- The shaft is of **stub shaft** design which is attached onto the motor shaft, therefore the pump runs off the motor bearings and does not utilize its own bearing assembly.
- The volute casing is attached to the motor by means of a **pump to motor bracket**.
- The entire pump design offers a **space saving option**.
- More economical, **cost saving design**.

Motor

We utilise Standard I.E.C flange mounted or foot and flange mounted, three phase 380 or 525 volt, totally enclosed fan cooled motors are used with either cast iron or aluminium frames.



Platinum Mine with a flushed mechanical seal arrangement



Platinum Mine - Acid plant



SP

SUBMERSIBLE PUMPS



APPLICATION

- Irrigation
- Paper and Pulp
- Sewage Waste Water
- Swimming Pools
- Textile
- Water

DESCRIPTION

- Designed to handle all applications where flooding has occurred and come in a variety of sizes that are widely used throughout industry.
- High efficiency impellers and volutes offer good performance.
- Leakage of the pumped media is eliminated by tandem mechanical seals running in an oil bath.
- Silicon carbide mechanical seals are fitted as standard.
- If required pumps can be fitted with moisture detection probes which will isolate the pump in the event of mechanical seal failure.
- The water tight electric motors incorporate heavy duty grease lubricated bearings.
- Available in single or three phase per application.
- RABA & RABU - general purpose designed for all drainage applications.
- RABL - designed for flood drainage. These pumps offer a high flow rate, and a low head.
- RAKL, RAKA & RAKF - designed to handle liquids which are chemically aggressive.
- RABFP & RABF - designed to handle raw sewage, available with guide rails and duck foot bends.
- RABST - fully submersible pumps designed to handle all applications especially slurries waste water and mine drainage.



RA PUMP RANGE	MINIMUM FLOW (m ³ /h)	MAXIMUM FLOW (m ³ /h)	MINIMUM HEAD (m)	MAXIMUM HEAD (m)	MAXIMUM TEMPERATURE
 RABA	6	40	2	15	40°C
 RABU	6	50	2	40	40°C
 RABL	6	600	1	5	40°C
 RAKL	6	60	1	4	40°C
 RAKA	6	90	5	40	40°C
 RAKF	6	150	4	30	40°C
 RABFP	15	480	4	30	40°C
 RABF	6	150	2	30	40°C
 RABST	30	300	4	30	40°C



HSC

HORIZONTAL SPLIT CASE PUMPS



APPLICATION

- Raw Water In-take Systems
- Power Generation
- Water Treatment Works
- General Industry
- Cooling Tower Applications

RA PUMP RANGE	MINIMUM FLOW (m ³ /h)	MAXIMUM FLOW (m ³ /h)	MINIMUM HEAD (m)	MAXIMUM HEAD (m)	MAXIMUM TEMPERATURE
HSC	70	20000	10	170	105°C

DESCRIPTION

- Axially split centrifugal pumps which are capable of generating high flow rates for various applications.
- The impeller which is situated between the bearings offers reliable and maintenance free operation.
- The double suction principal **results in high efficiencies** further resulting in economical operation in terms of power.
- Available in **sizes from 80mm to 2400mm** discharge and can generate heads up to **170 meter**.
- **Low NPSH requirements** which adds to their suitability for various applications.
- Available with gland packing or mechanical sealing.



Kwa-Zulu Natal - Evaporative Cooling Plant

OT

SELF PRIMING PUMPS



APPLICATION

- Sewage
- Raw water
- Sugar
- Pulp and Paper Industry

RA PUMP RANGE	MINIMUM FLOW (m ³ /h)	MAXIMUM FLOW (m ³ /h)	MINIMUM HEAD (m)	MAXIMUM HEAD (m)	MAXIMUM TEMPERATURE
OT	5	1200	3	40	80°C

DESCRIPTION

- Sizes available from 50mm to 300mm all based on the principle of self-priming which will exceed 6 meters at sea level.
- Ideally suited to handle raw **unscreened sewage**, **paper stock**, or any liquids **where solids are present**.
- **Back pull out** facility where the rotating assembly which carries the impeller, mechanical seal and bearing assembly can be removed without disturbing the suction and discharge pipe work.
- **Replaceable wear plates** in the event that abrasive application occurs.
- **Semi open impellers** which allow for the passing of large solids (76mm).



SKID BASE

TAILOR MADE COMPLETE SOLUTIONS



APPLICATION

- Pulp & Paper Industry
- Water & Wastewater Plants
- Chemical Industry
- Pharmaceutical Industry
- Food Industry
- Mining Industry
- Air Conditioning

DESCRIPTION

Rapid Allweiler can design and build a wide range of skid bases offering an **ALL IN ONE SOLUTION** for your pump, valve, meters, strainers, bellows, tanks, pressure vessels, frequency inverters, electrics and control panels etc. on one common base. It is as simple as 1,2,3.

1. Connect the power (to electric control panel if applicable).
2. Connect the pipe work to the suction and discharge manifolds.
3. Press **"GO"**

Skids bases are customised design per your requirements, though we have a wide range of experience in the:

- **Chemical Metering Skids** - for accurate injection, mixing, blending or treatment of any liquid or chemical.
- **Water & Wastewater Chemical Metering** - to

handle your specific wastewater requirements.

- **pH Control/Aggressive Chemicals** - pH control metering systems to handle harsh chemicals like sulphuric acid, sodium hydroxide, peroxide, caustic soda, urea and biocides.
- **Polymer Make down & Feed Systems** - Polymer blending and chemical systems integration mounted on custom designed skids.
- **Heat Transfer Skids** - Heat transfer skids are designed to meet your application.
- **Cooling Skids** - cooling of large industrial electrical panels to the cooling of process equipment in manufacturing, power generation and mining industry.



FIRE SYSTEM

APPLICATION

- Fire Fighting



DESCRIPTION

- Fire protection systems designed to meet the latest ASIB specification.
- These systems are designed with UL/FM approved components; to include pumps, motors, valves and controls.
- All components are mounted on a structural steel skid and designed with serviceability in mind.
- The systems can be designed with electric motors, diesel engines or a combination of the two all mounted on a common skid.
- These fire protection systems are factory built, hydrostatically tested and UL/C-UL third-party certified before shipment. The unit arrives on site, meeting all national and local codes, including NEC and NFPA guidelines.

Benefits

- UL/C-UL Labeled Systems
- UL Listed/FM Approved Components
- NFPA 20 & NEC 70 Compliance
- ASME 31-3 Certified Welders
- Prefabricated Skid Mounted Units
- Prefabricated Units with Enclosures
- Factory Test
- Single Source Responsibility



RENTAL UNIT



APPLICATION

- Mobile Dewatering

RA PUMP RANGE	MINIMUM FLOW (m ³ /h)	MAXIMUM FLOW (m ³ /h)	MINIMUM HEAD (m)	MAXIMUM HEAD (m)	MAXIMUM TEMPERATURE
Rental Unit	5	1080	3	40	80°C

DESCRIPTION

- Robust licensed trailer mounted.
- Diesel driven.
- Self-priming pump unit.
- Suction piping - 100mm diameter reinforced flexible hose, 6m long complete with suction strainer.
- Discharge piping - 100mm diameter lay flat hose, 100m long.
- Electric start.
- Monthly, Weekly, Daily Rates.

SCREW PUMPS



APPLICATION

- Power Generation
- Oil Firing
- Marine and Offshore Engineering
- Food Industry
- Chemical and Petrochemical Industries
- Pulp and Paper Industries

DESCRIPTION

- The ALLWEILER three screw pumps are used to pump oils or other lubricating liquids, non-lubricating liquids, or liquids with poor lubricating properties.
- The pumps are also characterized by very high efficiency and reliability. The liquid is moved continuously, without pulsation, turbulence, crushing or loss of lubrication. For overload protection a built-in-pressure relief valve is available (optional).
- The three screws have special shapes that create sealed chambers, the contents of which are continuously moved in a axial direction from the suction side to the discharge (high pressure) side as the screws rotate.
- Contactless and non-slip torque transfer greatly extends maintenance intervals and significantly increases the MTBF (Mean Time Between Failures).
- Single-channel, self-priming, with low noise level and very well suited for use with variable speed drives (frequency converters).
- A long service life due to hardened and ground screws and hydraulically driven idler spindles that are not subject to mechanical wear.
- Low maintenance due to the internal bearing being

lubricated by pumped liquid or external bearing grease lubricated.

- Easy to maintain with a complete insert unit that is removable, therefore the pump casing remains in the piping.

ALLWEILER SELECTION GUIDE

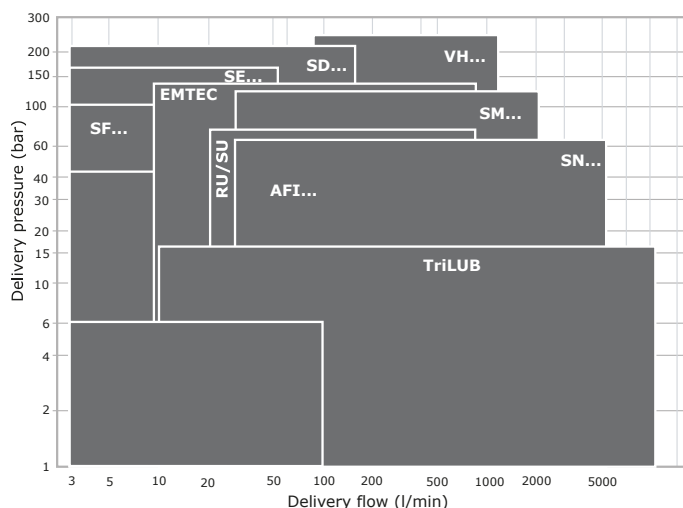



RA PUMP RANGE	MAXIMUM FLOW (ℓ/min)	MINIMUM HEAD (BAR-G)	MAXIMUM HEAD (BAR-G)	MAXIMUM TEMPERATURE
	5300	*	100	250°C
SN				
	5300	*	120	250°C
SM				
	820	*	50	70°C
RU				
	820	*	80	70°C
SU				
	1300	*	280	150°C
VH				
	880	*	16	150°C
TRILUBE				
	833	*	80	100°C
TRITEC				
	900	*	130	80°C
EMTEC				
	110	*	40	150°C
ALLFUEL				

* Minimum head subject to viscosity of pumped media.

IMO PUMPS



APPLICATION







- Crude Oil Transportation
- Power Generation
- Hydraulic Elevator
- Fuel Oil Transport & Burner Service
- Machinery Lubrication
- Commercial Marine & Navy
- Refinery Processes
- Chemical Processing
- Lube Oil Systems

DESCRIPTION

Imo Pump manufactures rotary positive displacement three screw pumps.

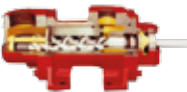



Benefits

- Internal bearings are hydraulically balanced thus there is no load on the bearings, either axially or radially.
- Operational savings can be achieved in the choice of a more compact pump as well as flexibility in handling changes to your fluid or parameter requirements.
- Installation flexibility.
- Low pressure pulsations and quiet operation.
- Capable of handling cold start and hot run without any malfunction.
- Low maintenance.
- Extended service life with minimum wear.
- Due to the monoblock design installation is simple ensuring pump alignment with driver.
- The IMO three screw pump is ideal for handling all types of viscous fluid such as diesel fuel, lube and hydraulic oils.
- **OptiLine** is a magnetically driven range eliminating leaks by incorporating a complete enclosure where there is no shaft extension into open air thus there is no need for a conventional seal.
- **"Canned"** design where extremely strong rare earth permanent magnets are fixed to the pump shaft inside the "can" and are driven by a similar set of permanent magnets on the driver shaft outside the "can".

PUMP RANGE	MAXIMUM FLOW (ℓ/min)	MINIMUM HEAD (BAR-G)	MAXIMUM HEAD (BAR-G)	MAXIMUM TEMPERATURE
 ACE	9	*	10	10°C
 3E	22	*	10	121°C
 3G	47	*	17	107°C
 3D	90	*	34	107°C
 C324	204	*	34	260°C
 T324	181	*	48	121°C
 6D	90	*	103	121°C
 4T	45	*	103	82°C

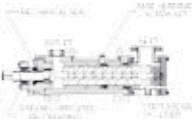
* Minimum head subject to viscosity of pumped media.



PUMP RANGE	MAXIMUM FLOW (ℓ/min)	MINIMUM HEAD (BAR-G)	MAXIMUM HEAD (BAR-G)	MAXIMUM TEMPERATURE
 8L	249	*	103	121°C
 12D	90	*	152	121°C
 6T	45	*	172	82°C
 6U	45	*	172	82°C
 12L	22	*	310	121°C

* Minimum head subject to viscosity of pumped media.

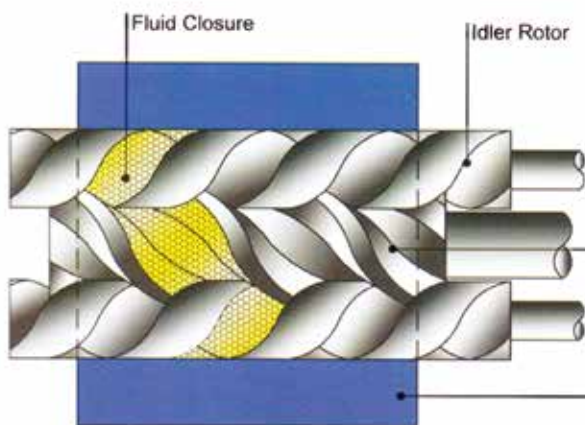

Figure A

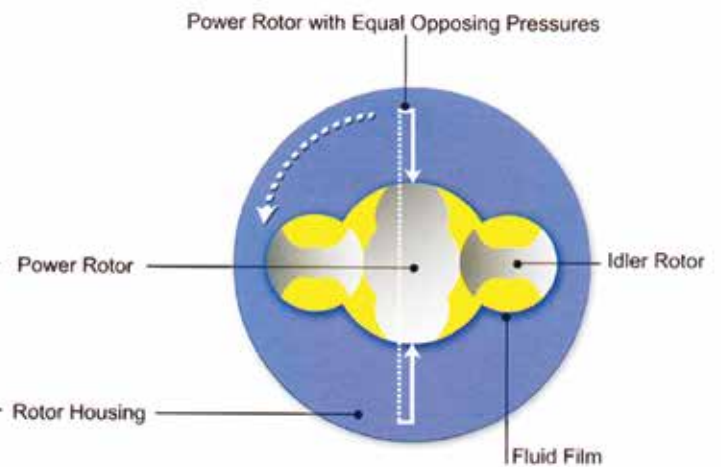
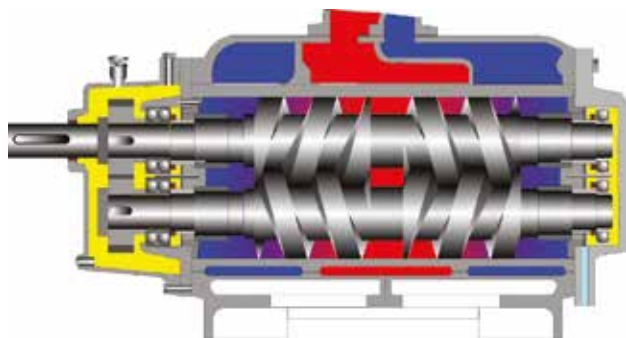

Figure B

TWO SCREW PUMPS



APPLICATION

- Chemical and Petrochemical Industry
- Tank Farms
- Power Plants
- Offshore
- Refineries
- Shipbuilding and Marine
- Soap
- Food & Beverage
- Plastics
- Sugar Industries

RA PUMP RANGE	MAXIMUM FLOW (ℓ/min)	MINIMUM HEAD (BAR-G)	MAXIMUM HEAD (BAR-G)	MAXIMUM TEMPERATURE
TWO SCREW PUMPS	2500	100	800	400

- Houttuin, a Colfax Business Unit, developed the original pump design that is the blue print for low pressure, twin-screw positive displacement rotary pumps.
- Houttuin employs specially designed and built CNC machines to manufacture its complex screw shafts to the extremely high tolerances necessary.
- All pumps under go both a hydrostatic test and run test; approximating as near as possible the actual duty conditions.
- **200 series:** Horizontal and vertical double entry twin screw pumps, covering a flow range up to 2500 m³/h at a maximum pressure of 25 bar.
- **211/215 series:** Vertical double entry twin-screw pumps for lubricating purposes where space is limited ideally suited for the marine industry.
- **Engineered series 200/300:** Horizontal twin screw pumps, each pump being a one off piece or part of a small series, designed and constructed according to customer specifications on, for instance, high and low viscosities, large capacities and high pressures (up to 80 bar).

Product range

- Houttuin twin geared screw pumps are manufactured in small standard series or tailor made.
- The standard pumps are divided into four product groups:
- **100 series:** Horizontal single entry twin screw pumps for low range pressures (max. 10 bar) and limited capacities of aggressive chemical liquids.
- In addition to standard pumps, the company specializes in **tailor made solutions** which meet the specific demands of each branch of industry.

PC

PROGRESSIVE CAVITY PUMPS

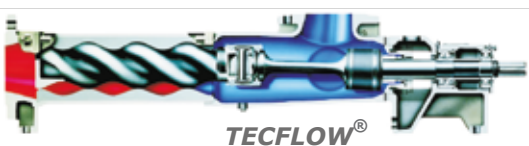

APPLICATION

- Food and Beverage
- Paper and Cellulose
- Soaps and Fats
- Paint and Lacquer
- Sewage and Waste Water Treatment
- Chemical and Petrochemical Industry
- Agricultural
- Ship building
- Sugar
- Pharmaceuticals

RA PUMP RANGE	MAXIMUM FLOW (ℓ/min)	MINIMUM HEAD (BAR-G)	MAXIMUM HEAD (BAR-G)	MAXIMUM TEMPERATURE
PC	720	10	240	150°C
ALLCLEAN	30	10	200	200°C
TECFLOW	190	10	40	40°C

DESCRIPTION

- The progressive cavity pumps are self-priming, rotary displacement pumps for handling and dosing low to high-viscous, neutral or aggressive, pure or abrasive, gaseous liquids or liquids which tend to froth, even with fibre and solids content.
- The pumping elements are the rotor and the stationary stator. Allweiler produces stators and rotors at their factory in Germany.
- Excellent self-priming features, even with dry substance content up to 45%.
- Available in a variety of materials making them ideal for industrial use. Stainless steel (CIP versions) are available for food and beverage production and pumping of pharmaceuticals and cosmetics.
- Allweiler is one of only a few manufacturers that produce every part of its progressive cavity pump at its plant in Germany.
- Stators are particularly important and must be carefully matched to the pump liquid.
- With 20 different elastomer mixtures, the client always gets the combination that will be most economical for the application.



ALLOPTIFLOW®

- The ALLOPTIFLOW series is the product of decades of optimization. Embroidering Allweilers experience using progressing cavity pumps in a wide variety of applications and industries.
- Optimization of the pumped liquid flow, distribution of Forces and lubricant flow ensure a long service life and very high operating efficiency.
- ALL-OPTIFLOW saves a significant amount of energy in any situation. Numerous design details boost efficiency and lower operating and maintenance costs. Standardisation and a service friendly design (including accessible shaft seals without pipeline disassembly) save time and reduce process interruptions.
- The new 2/3 lobed pumping elements have significantly greater power density than the 1/2 lobed pumping elements and generate about twice as much flow volume at the same speed.
- Pressure casing and stator suction casings are held together by external tie rods. The suction casings are of particularly favourable hydro-dynamical design. The sizes 381 to 5001 are supplied with staggered cleaning ports. The stator being vulcanised into a tubular casing, is provided at both ends with external collars vulcanized to it. They provide a safe seal to the suction casing and the pressure casing and also protect the stator material against corrosion.

ALLCLEAN®

- For all types of sensitive media.
- With ALLCLEAN you can pump with care and precision and meet the strictest hygienic standards.
- If your primary objective is to pump sensitive and high-grade media while maintaining the highest standards in hygiene, cleaning efficiency and official certification, the ALLCLEAN range will be an ideal choice.
- Cleaned by means of throughput rinsing without dismantling the pump, leaving them completely free of residue and therefore of bacteria ("CIP": "Cleaning in place" and "SIP": "Steaming in place").
- **Shaft Seal**
By maintenance-free, non-balanced and single acting mechanical seal. Installation space for the mechanical seal according to DIN 24960.
- **Bearing**
The drive shaft/hollow shaft is carried in reinforced bearings of the geared motors or variable speed gears, which at the same time absorb any occurring axial forces.

TECFLOW®

- TECFLOW® Pumps are standard eccentric spiral pumps specially designed for wastewater and wastewater treatment technique. These pumps move liquids with fibrous and solid components of up to 10% dry substances.
- **Drive**
Geared motors or variable speed gears either with or without explosion protection can be provided.



ALLWEILER®

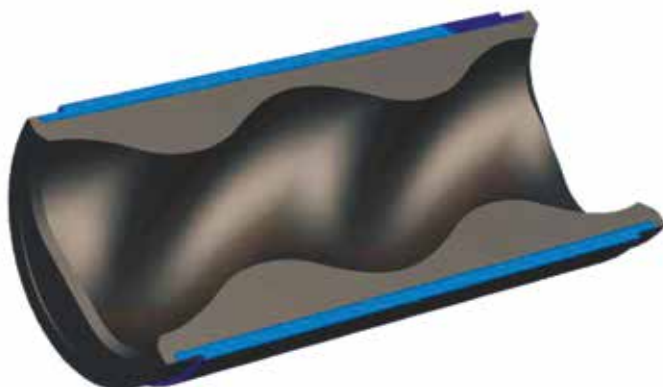

ENERGY COSTS
REDUCED
up to 15%

MAINTENANCE
COSTS REDUCED
up to 15%

LONGER
SERVICE LIFE
up to 300%

ALLDUR®

- Stators made from Allweilers exclusive and proprietary material ALLDUR play a special role in the selection of materials.
- The composition of ALLDUR is adapted to provide maximum resistance to mechanical influences. Even when used in continuous operation to pump highly contaminated wastewater loaded with solids, wear and tear is extremely low.
- The new stator is also highly elastic and exhibits high tensile strength.
- It has high tear-growth resistance and can be used across a wide temperature range.
- You can expect up to 300% longer service life, less downtime and lower maintenance costs from ALLDUR.



Progressive Cavity Pump



MACERATORS

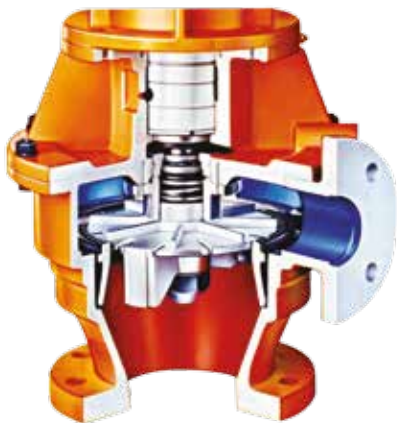

APPLICATION

Shreds fibres and solids contained in media and make them pumpable (to be used in conjunction with Progressive Cavity pumps).

RA PUMP RANGE	MINIMUM FLOW (m ³ /h)	MAXIMUM FLOW (m ³ /h)	MINIMUM HEAD (m)	MAXIMUM HEAD (m)	MAXIMUM TEMPERATURE
Macerators	80	160	100	100	80°C

DESCRIPTION

- Shreds any solids contained in liquids such as wood, textiles, plastic, paper, rubber, bone, fur, glass etc, making them pumpable.
- Used for chopping, mixing and process technology applications in communal and industrial wastewater treatment plants.
- Used in the treatment of wastewater products in every industrial segment.
- The chopping elements are the rotating impeller combined with the stationary cutting ring.
- The impeller has replaceable wear resistant cutting tips.
- Provides delivery head increase of between 3 to 5m depending on design of macerator.



Macerator System

PERISTALTIC PUMPS



APPLICATION

- Waste Water Treatment Plants
- Chemical and Petrochemical Industry
- Paper Chemical Industry
- Paper and Pulp
- Cellulose
- Textile Industry
- Paint
- Pharmaceutical Industry

RA PUMP RANGE	MINIMUM FLOW (m ³ /h)	MAXIMUM FLOW (m ³ /h)	MINIMUM HEAD (m)	MAXIMUM HEAD (m)	MAXIMUM TEMPERATURE
Peristaltic Pumps	10	60	1	16	80°C

DESCRIPTION

- They are dry self priming, sealless, rotary displacement pumps.
- They are suitable for pumping liquids with high or low viscosity, neutral or aggressive and clean or abrasive with high solid content.

Benefits

- Short flexible-clamped pump hose for extended life.
- Efficient pressure and priming characteristics through hoses with several textile-reinforced elastomer options.
- Gentle compression of pump hose by adjustable sliding blocks.



Peristaltic Pumps

PROPELLER PUMPS

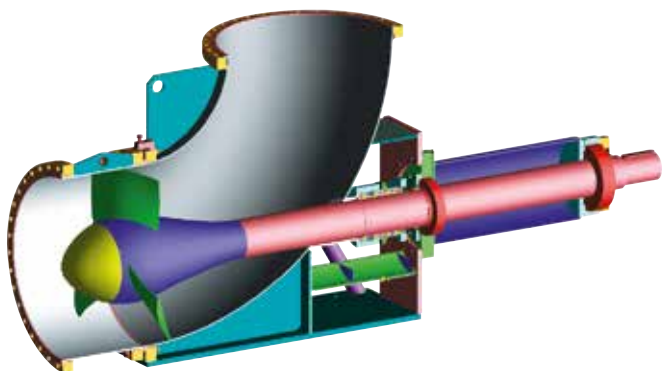

APPLICATION

- Sewage and Water Treatment Plants
- Chemical Industry
- Processing Industry
- Agricultural (Flood Irrigation)

RA PUMP RANGE	MINIMUM FLOW (m ³ /h)	MAXIMUM FLOW (m ³ /h)	MINIMUM HEAD (m)	MAXIMUM HEAD (m)	MAXIMUM TEMPERATURE
Propeller Pumps	300	50000	1.5	20	40°C

DESCRIPTION

- They are used to pump **large volumes** with a relatively **low delivery head**.
- They deliver various liquids in chemical and process type applications.
- Widely used in wastewater engineering, as recirculation pumps or for handling return sludge or rainwater.
- Used in the reclamation of portable water (e.g. in seawater desalination plants).
- The pumps are available as horizontal or vertical pumps. They can be suspended into the pipeline or horizontally foot mounted.
- Type of construction, materials, installation and drive can be adapted optimally to the operation and assembling conditions.
- The ALLTRIM series was designed especially for shipbuilding applications. These are space-saving

inline pumps and have integrated motors and reversible hydraulics.



Propeller Pump



IN-1000

ELECTRONIC & FULLY AUTOMATED MONITORING SYSTEM

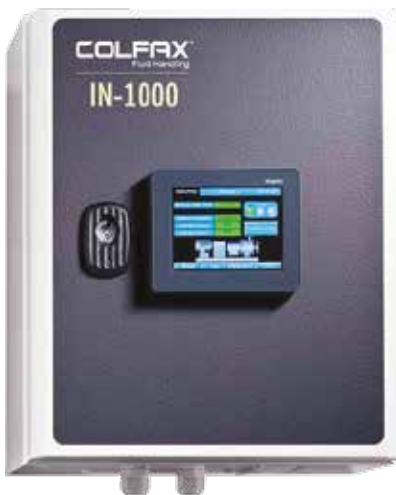

APPLICATION

- Increase the safety of thermal oil systems
- Optimize cooling-water processes
- Logging of operating points for generation of load profiles



DESCRIPTION

Intelligent Pump Monitoring

- Condition and operation monitoring for greater safety and lower operating costs.
- IN-1000 is an electronic and fully automated monitoring system. The modular design of IN-1000 permits easy integration into pump systems, with pre-configured settings that are the foundation of rapid, individualized startup. IN-1000 may be retrofitted at any time and allows central monitoring of up to 21 pumps with one control.
- The new Smart Technology IN-1000 series is ready to handle anything from straightforward condition monitoring to more complex monitoring activities, including operation monitoring of multiple pumps for simultaneous fulfillment to ensure your safety and operating cost requirements are met.
- Operations are monitored continuously and automatically, with activity logging and storage for evaluation of your process. If unusual operating

conditions occur, both audible and visual alerts are triggered and shown on a graphics-capable color display.

- Because of these capabilities, maintenance and repairs can be planned in advance, there are no unplanned production downtimes or consequential damages, and maintenance intervals are extended. As a result, expenses for maintenance and spare parts go down and the long service life of each Rapid Allweiler pump/motor assembly can be utilized to its fullest.

Modular Diagnostic System

- Increase safety, maximize efficiency, and minimize costs.



Pump system monitoring for elevated protection

- The early phases of mechanical seal damage is detected by collecting and monitoring the normal leakage that is required for regular operation of this seal type.
- Mechanical oscillations are monitored and continuously compared to two threshold values defined by DIN/ISO 10816-3 and -7. As a result, vibrations during operation are detected before they can cause damage.
- IN-1000 monitors the condition of the bearing. Changes in bearing temperature are evaluated to indicate potential wear of the bearing.

Additional digital and/or analog sensors (based on specific requirements) monitor parameters such as pressure and liquid temperature.

Two Level Alert System

Maintenance personnel receive information about disturbances and/or irregular operating conditions in plain language, accompanied by visualizations on the graphical display. If the warning threshold for one of the monitored parameters is reached, a notification appears. Warnings indicate that maintenance should be planned. If the alarm threshold for one of the monitored parameters is reached or exceeded, the system will respond according to its configuration, e.g. automatic shutdown or switchover to a different pump. Alarms indicate that maintenance and/or repairs are necessary.

Data logging

IN-1000 records all sensor data with the date and time, which can be exported to a spreadsheet for evaluation purposes. Data logging identifies the pump's current operating conditions. With this information, load profiles, pressure curves, or temperature load curves, for example, can be generated in order to uncover potential for optimization. The causes and triggers of the error and alarm messages can be derived directly from the recordings.

IN-1000 IN USE

© 123RF Stock Foto

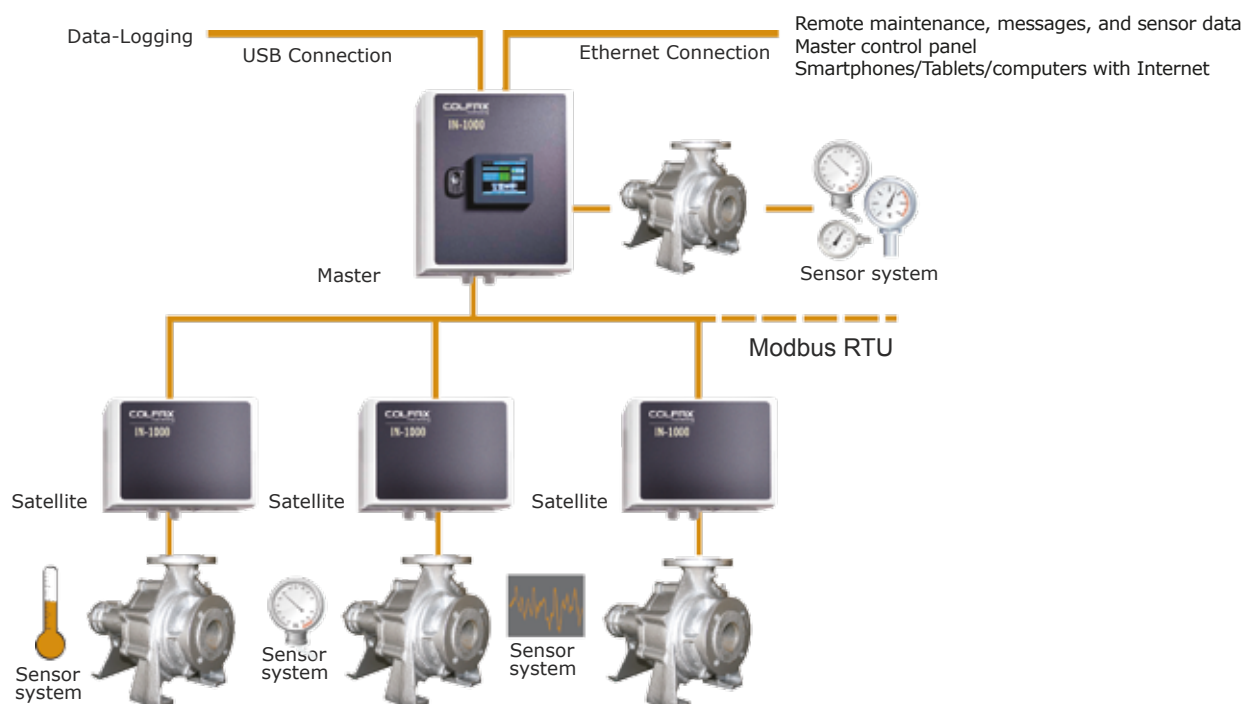

ALLFUEL

THREE SCREW PUMP



APPLICATION

- Transfer and closed-loop pumps as well as booster and burner pumps in oil-fired systems.
- Feeder and circulation pumps for fuels and lubricants in Marine environments.
- Feeder and filling pumps in tank systems.
- Transfer pumps for all lubricating liquids in industrial environments,
- Lube-oil pumps for gearboxes, motors, and hydraulic systems.

DESCRIPTION

- The new Three Screw Pump for moving oils and other lubricating liquids. Up to 6 or 40 bar.
- The ALLFUEL product family is ideally suited to the requirements of pumping lubricating liquids.
- Twin unit contains central ball valve and definitive valve positions for safe and reliable switching.
- Innovative design causes the liquid to flow from inside the filter to outside. Dirt and metal chips remain in the filter and cannot get into the pump casing.
- The filter can be removed for cleaning without draining the liquid.
- Twin unit contains central ball valve and definitive valve positions for safe and reliable switching.
- Innovative design causes the liquid to flow from inside the filter to outside. Dirt and metal chips remain in the filter and cannot get into the pump casing.

Benefits

- Several variations for optimal adaptation.
- The installed pump requires little space.
- Easy to operate and therefore safe in operation.
- Maintenance is completed quickly, lowering costs.

A variety of construction types, installation variations, and material combinations make them universally suited for use as:



LSC

LUBRICATION SYSTEM

What is Oil Mist?

Oil Mist, is a clean, lean mix of oil lubricant particles suspended in air. Made up of 1 part oil to 200,000 parts air. The particles obtained measure from 1 to 3 microns.

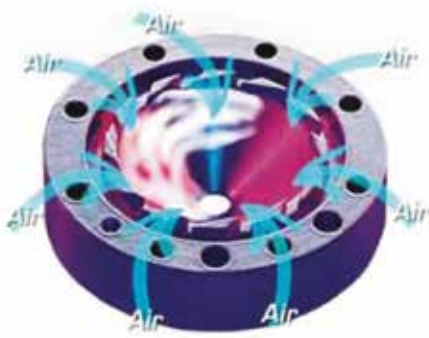

Model "IVT" (Complete Plants)



Model "CH" (Equipment Sectors)

Characteristics

- There are no moving parts in the head generator which is why it is maintenance free.
- Clean Mix 17/15/12 or better, ISO 4406.
- Cool Mix (<16°C) when exiting the mist generator.
- Dry Mix (<50 ppm or less of water).
- 1 part oil to 200,000 parts of air = 5 ppm of oil
- A mix of clean air and oil since both the oil and air are filtered and dried.
- Non flammable because of the air/oil mix.
- Non toxic according to the OSHA, NIOSH and IPPC standards.
- Can be transported within a radius of on average 150m based on the standards of the process plants.



The importance of Oil Mist lubrication

Oil Mist Lubrication has revolutionized traditional lubrication methods and has become widely used in industry since 1979, the year in which the "Vortex" was included in the system, which considerably improved the quality and reliability of the Mist Lubricant and also modernized the control and monitoring systems in the equipments generators.

Benefits

- **Reliability of Production** - Increases the plants operational reliability by increasing that of the equipment.
- **Safety of Personnel and Facilities** - Automation reduces exposure to toxic vapours (H₂S, HF, Hydrocarbons, etc.) and reduces risks of accidents in plants by reducing routine lubrication and maintenance.
- **Saves cooling water** - The dissipation of heat through the continuous mist lubricant flow, substantially reduces the necessity of cooling water in bearing housings.
- **Modernization** - This best applicable technique is applied to the lubrication of bearings. In the Design of new mechanical tribo-systems it is taken into consideration (electric motors and centrifugal pumps) following ISO 13709, API 610, API 541 API 686 etc.
- **Rationalise costs** - Substantially reduce costs direct and indirect (parts, maintenance, inventories, repairs, etc.)
- **Ecology** - Reduce environmental contamination through degraded oils and greases, through reduced consumption.
- **Energy Efficiency** - Reduce the demand and consumption of energy in electric motors from lower co-efficients of friction in the bearings, this applies to driven equipment and not only to motors.
- **R O I** - Due to its integrated impact the economic benefits are very high, which provides a very rapid return on investment.
- **Service** - Total back-up provided during the operation of the system, which is included in an integrated service contract.

Successful cases, stated by customers.

Pillow blocks

The problems in the pillow blocks of the equipment in our plant have vanished after connecting a reliable Oil Mist system.



Petrochemical Complex, Mexico

Motors

We have motors of 125 and 1100 HP working efficiently with oil mist lubrication. In these the consumption of electricity has decreased by on average 5% and the bearings operate at lower temperatures. The maintenance has also been reduced to a minimum.



Gas Complex, Tabasco, Mexico

Steam Turbines

Thanks to the oil mist systems applied to preserve the bearing housings with plain bearings, avoiding the entrance of contaminants and water, the degradation of the oil has been reduced, prolonging in this way its useful life and the reliability of the equipment.



Refinery, Brazil



ALLWEILER®

Allweiler GmbH, a Colfax Business Unit, is Germany's oldest pump manufacturer and serves many different industries around the world. Allweiler is a 35% share holder of Rapid Allweiler, thus making us the sole distributor of Allweiler products in sub Saharan Africa.

More than 150 years of experience, coupled with German quality standards, provide our foundation for creating the highest precision products available. Modern design and production methods are other major elements of our success. Accredited quality assurance system ensures the long-term reliability and efficiency of every pump we produce. Our own foundry produces high quality castings and uses various materials available only through Allweiler.

Allweiler are continuously investing in design and production methods while simultaneously promoting employee know how. As a result you can be sure that use of selected innovative technologies will keep your pump reliably and continuously operating with little need for maintenance. In addition, proper material selection, precise construction, and German quality production will keep your life cycle costs low.

BARIC®

Baric, a Colfax Business Unit, with over 35 years of experience, can assist you with:

- All aspects of the design & manufacture of bespoke API and Non API Lube, Seal & Control Oil Systems for the world market, taking account of unique Customer/Project specific requirements.
- Design & manufacture of Standardised API and Non API Lube, Seal & Control Oil Systems to meet with your particular range of OEM Products.

PORTLAND®

Portland Valve, a Colfax Business Unit, founded in 1973. Portland Valve (PV) has been a contractor to the US Navy

and a major subcontractor to public and private ship yards, Naval Inventory Control Point (NAVICP), Defense Logistics Agency (DLA), Regional Maintenance Centres (RMCs), Defence Industry Supply Centres (DISCs), Original Equipment Manufacturers (OEMs) and Master Ship Repair Contractors. For over 30 years Portland Valve products have been put to the test in every ocean of the world, under the most severe conditions.

Portland Valve products include valves, actuators, components, sub-assemblies and fabrications, which are primarily installed on U.S. Navy ships. PV also manufactures products for Army systems and various commercial applications including power generation, aircraft, electronics, oil & gas and commercial shipbuilding industries.

ROSSCOR®

Rosscor International B.V., a Colfax Business Unit, is a premier global supplier of multiphase pumping (MPP) technology and other highly-engineered fluid handling systems for the Oil & Gas industry. As a pioneer in MPP development nearly 20 years ago, Rosscor delivered the first fully integrated turnkey MPP system. A technology leader today, Rosscor has over 70 MPP installations worldwide.

Rosscor's MPP technology includes a robust twin-screw multiphase pump combined with a reliable control and monitoring system. It boosts the full well stream mixture of oil, water, gas and solid particles from the well cluster to a central production facility via a single pipeline.

This significantly reduces capital expenditures (CAPEX) by reducing the need for equipment at the wellhead, eliminating the need for separators, gas compressors, gas flaring, storage tanks, separate liquid pumps and field-installed vapour recovery systems, thereby reducing the required real estate and lowering construction costs. It also reduces operating expenses (OPEX) by increasing production by establishing a lower, maintained wellhead pressure.



In addition, by reducing equipment at the wellhead, maintenance and inspection are significantly reduced. Environmental benefits are also realized through the elimination of gas flaring, greatly reduced spill potential and a smaller footprint that reduces natural habitat disturbances. MPP technology is ideal for wellheads located in harsh climates or challenging environmental conditions.

Leveraging their gas handling expertise, Rosscor also provides skid-mounted gas compression systems and natural gas chillers for the upstream sector. These capabilities provide Colfax with the tools to effectively manage the needs of production field operators in handling gas, oil or a multiphase mixture.

TUSHACO®

Tushaco, a Colfax Business Unit, serves the oil and gas, power generation, marine, food, beverage, steel, cement, paint, chemical, pulp and paper industries and effluent treatment plants.

The applications are vacuum residue fuel transfer pumps; seal oil, jacking oil and fuel pressurizing pumps; cargo, main engine and lube oil pumps; sugar syrup and chocolate transfer pumps; hot strip mill, cold rolling mill and lube oil circulation pumps; sludge feed pumps; centrifuge decanter pumps; kiln firing pumps; resin and paint transfer pumps; pulp transfer and coating pumps; dye and chemical transfer pumps.

Tushaco manufactures seven different types of rotary positive displacement pumps in India:

- Eccentric Helical Rotor Pump
- Two-Spindle Screw Pump
- Three-Spindle Screw Pump
- Internal Gear Pump
- External Gear Pump
- Internal Lobe (Trochoidal) Pump
- Shuttle Block Pump (Rotary Piston)

It also manufactures:

- Basket Type Suction Strainer
- Lube Oil and Fuel Oil Skids

ZENITH®

Since 1920, Zenith, a Colfax Business Unit, has offered engineers pulse free precise flow pumps with low NPSH (net positive suction head) requirements. These positive displacement pumps utilize an inter meshing gear system that rotates within a housing. As the gears rotate, a void is created drawing the liquid into the pump. The tight operating tolerances of the gears and available material options for the housing provide significant advantages in fibre, polymer processing, adhesives, paints, food and other markets.

Located in Monroe, NC, the Zenith manufacturing facility is ISO 9001:2000 Quality Management Certified.

WARREN®

Warren Pumps, a Colfax Business Unit, is a nearly 110-year old engineering firm that specializes in solving unique pumping applications for the US Military as well as for a wide variety of industrial and marine customers.

Our emphasis is on twin-screw positive displacement pumps for industry and a wider variety of pumping technologies for the military, including centrifugal, gear, piston and twin screw.

Warren brings a unique ability, not only to designing pumps, but also to the manufacturing, packaging, testing and servicing of products. Our strength comes from years of experience in solving pumping application problems and proving their benefits in the field. A typical Warren pump is located in services where operational reliability is of the utmost importance and can be found on land and sea in remote corners throughout the globe.

Warren Pumps, headquartered in central Massachusetts, holds the following certifications: ANSI/ASQC Q 9001, Mil -I-45208, and ISO 9001.

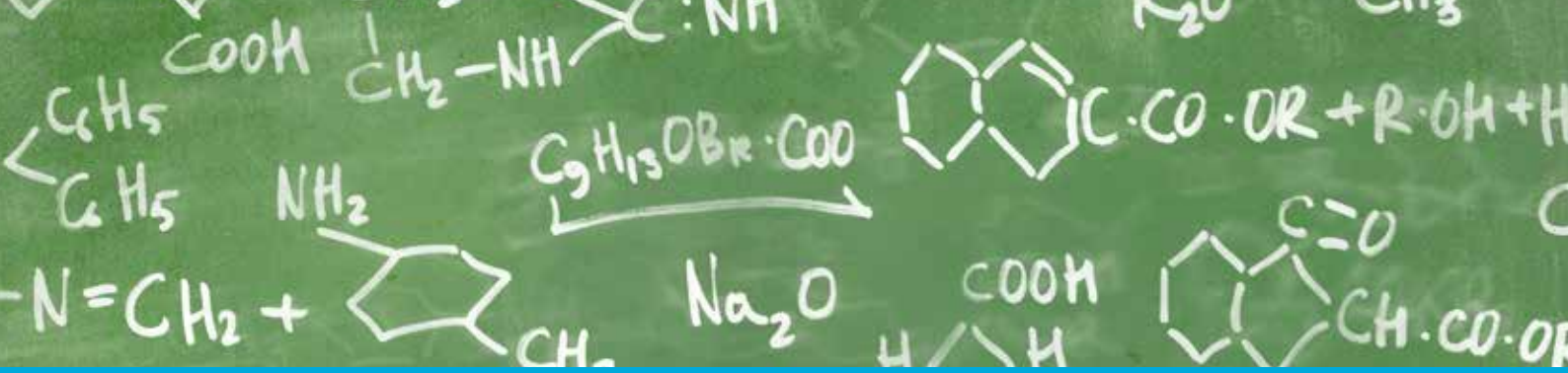

BASIC FORMULAS

H= Head(m)

Q = Flow(m³/h)

CAPACITY

$$l/sec \times 3.6 = m^3/h$$

$$m^3/h \div 3.6 = l/sec$$

$$Imp\ gpm \times 0.2271 = m^3/h \quad m^3/h \times 4.403 = Imp\ gpm$$

$$US\ gpm \div 0.246 = l/min \quad l/min \times 0.246 = US\ gpm$$

$$10000\ kg/hr = \frac{10m^3h}{Density(SG)}$$

HEAD/PRESSURE

$$Ft \div 3.28 = m$$

$$m \times 3.28048 = Ft$$

$$Bar \times 100 = kpa$$

$$m \times 9.805 = kpa$$

$$kpa \times 0.102 = m$$

$$m \times 0.098 = Bar$$

$$Bar \times 10.19 = m$$

$$m \times 1.45 = psi$$

$$psi \times 6.895 = kpa$$

POWER

$$hp \times 0.746 = kw$$

$$kw \times 1.340483 = hp$$

$$kw\ abs = \frac{Q \times H \times SG}{367 \times Eff(\%)}$$

$$kw = \frac{Amps \times Volts \times Power\ Factor \times 1.732}{1000}$$

$$RPM = \frac{Hz \times 120}{No\ of\ Poles}$$

$$Hz = \frac{RPM \times No\ Of\ Poles}{120}$$

$$Velocity\ m/sec = \frac{Q \times 353.63}{(Pipe\ Dia)^2}$$

EFFICIENCY

$$EFF(\%) = \frac{Q \times H \times SG}{367 \times kw(abs)}$$

Eff = Pump Eff%

Density = SG

TEMPERATURE

$$Deg.C = (deg.F-32) \times 0.556$$

$$Deg.F = (1.8 \times deg.C) + 32$$

PERIPHERAL SPEED

$$Peripheral\ Speed(Impeller) = \frac{imp.dia.(mm) \times \pi \times N(Rpm)}{60\ 000}$$

VISCOSITY

vis Viscous Liquid

w Water

Given: Qvis in m³/h kinematic viscosity v in mm²/s

Hvis in m

pvis in kg/dm³

$$Qw = \frac{Qvis}{CQ}$$

$$Hw = \frac{Hvis}{CH}$$

$$Qw = C\% \times \%w$$

$$Pvis = \frac{Qvis \times Hvis \times Pvis}{367 \times Eff(\%) \times vis}$$

CENTRIFUGAL AND AXIAL FLOW PUMP AFFINITY LAWS:

Speed changes & impeller diameter remains the same:

$$Q1/Q2 = N1/N2$$

$$H1/H2 = (N1/N2)^2$$

$$P1/P2 = (N1/N2)^3$$

Impeller diameter changes and speed remains the same:

$$Q1/Q2 = D1/D2$$

$$H1/H2 = (D1/D2)^2$$

$$P1/P2 = (D1/D2)^3$$

FRICION LOSS CHART

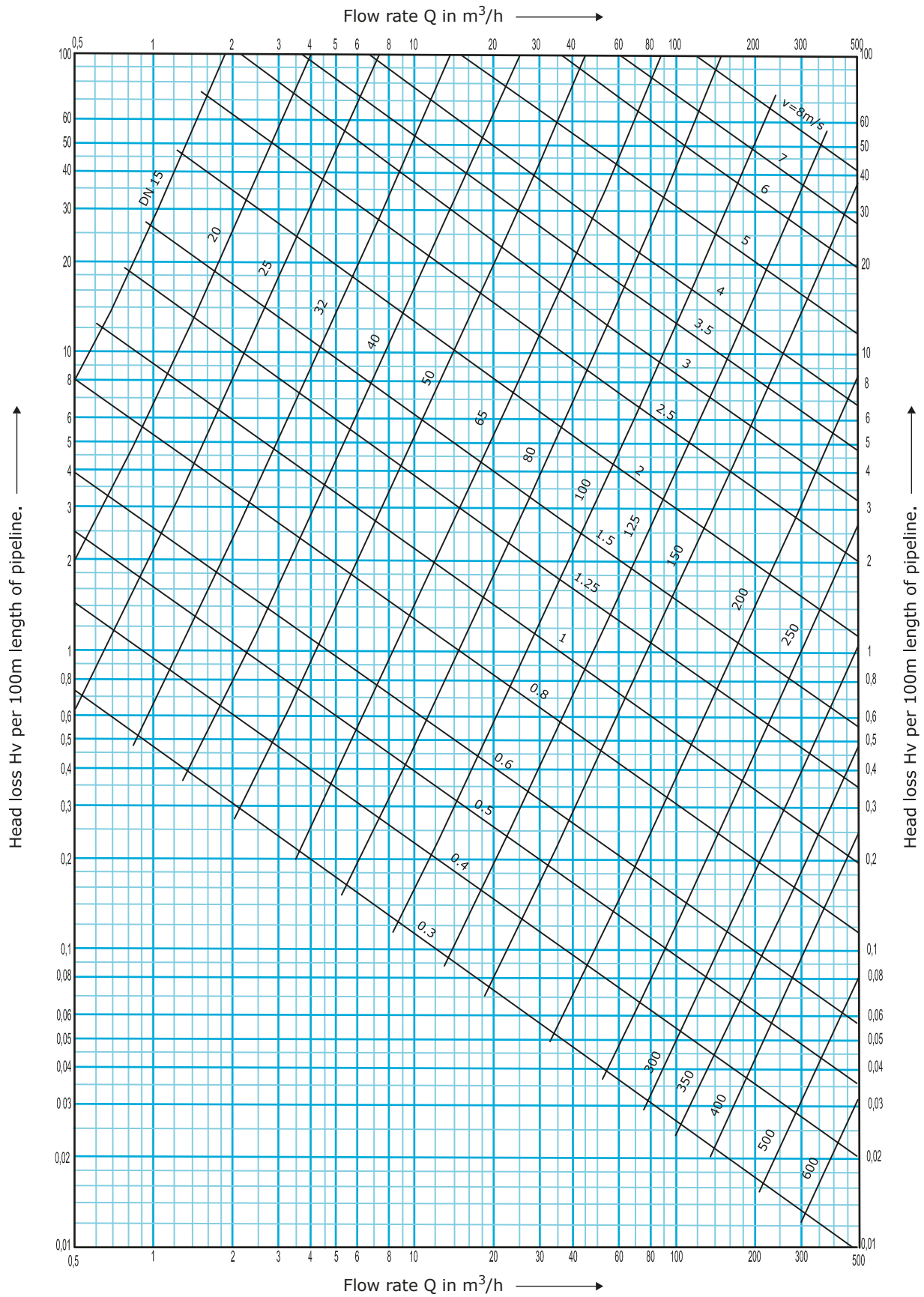

The loss of pressure given by the chart is applicable to new cast iron pipes made by rolling and welding steel plate. For new solid and rolled steel tubes the resistance to flow is about 0.80 times that given by chart. For fairly old rusted C.I. pipes the actual pressure drop may be as much as 1.25 times the figure calculated from the chart. For tubes with light incrustation, the flow resistance increases to about 1.7 times the value shown on the above chart and should be calculated for the actual (not the nominal) diameter of the incrustated pipes, for heavily incrustated pipes the pressure loss can only be determined by tests. Deviations from the nominal diameter have a considerable effect on the result. For example a decrease in the required diameter by about 1.3 times for the same degree of roughness.

RAW

Rapid Allweiler Way

COMMUNICATION

- Define Requirement
- Provide Solution
- Order Confirmation/Weekly Feedback
- Utilize MRP and KANBAN processes to ensure alignment between all departments

QUALITY

- ISO 9001:2008
- Continuous QC Inspection in Manufacturing Process
- External suppliers vetted and quality checked

COMMITMENT

Our Core Value System:

-  Can Do
-  Growth Orientated
-  Passion
-  Respect
-  Ethical
-  Trust

SATISFACTION

- Delivered as Promised, Quality and on Time
- Engage in ongoing feedback
 - Once Product is Delivered
 - When Product is Commissioned

" Delivered as Promised "



SOME OF OUR CLIENTS





08600 RAPID

10 Girder Street • Isando • 1601
T: +27 11 573 7400 • **F:** +27 11 974 8757

www.rapidallweiler.co.za